

 PENTAIR

ONGA®



BLAZE MASTER

DISTRIBUTOR CATALOGUE



BLAZEMASTER

CONTENTS

BENEFITS - NOMENCLATURE	3
PERFORMANCE - BLAZEMASTER SINGLE	
B55H / B55BS / B65H / B65BS / B80BS / B10BS	4
PERFORMANCE - BLAZEMASTER TWIN	
BM55H / BM55BS / BM65H / BM65BS / BM80BS / BM10BS	5
PERFORMANCE - BLAZEMASTER DIESEL	
B48Y / B48Y / B70Y / BM70Y / B10YE / BM10YE	6
PERFORMANCE - BLAZEMASTER UTE PACKS	
FIREPOD / MINIBLAZE	7
PERFORMANCE - ENGINEMASTER CENTRIFUGAL	
MODEL 384 / GP960	8
PERFORMANCE - ENGINEMASTER JET ASSISTED	
OJ700E / OJ700ES / OJ800E / OJ800ES	9
DIMENSIONS	
BLAZEMASTER SINGLE / TWIN - Drawings	10
DIMENSIONS TABLE	10
MODEL 384 / GP960 / OJ700E / OJ800E - Drawings	11
TECHNICAL - BLAZEMASTER	
MATERIALS OF CONSTRUCTION	12
TECHNICAL DATA	12
TECHNICAL - ENGINEMASTER	
MATERIALS OF CONSTRUCTION	13
TECHNICAL DATA	13
TECHNICAL - INJECTOR SIZING	
OJ700 / OJ800 - Shallow well	14
OJ700 / OJ800 - Deep well	15
SELECT & INSTALL CONVERTIBLE JET PUMPS	16
SPARE PARTS	
BLAZEMASTER SINGLE	17
BLAZEMASTER TWIN	18
MINIBLAZE	19
MODEL 384 / GP960	20
OJ SERIES	21
ACCESSORIES	
VITON SEAL KITS / ROLL FRAMES / HOSE KITS	22
OPTIONS FOR DIESEL ENGINES	23
OPTIONS FOR L-SERIES AIR COOLED ENGINES	23

BLAZEMASTER

BENEFITS - NOMENCLATURE

Onga offers a wide range of Engine Drive pumps to provide the best possible solution to a range of needs in areas inaccessible to power. Like Onga pumps, Honda, Briggs & Stratton (petrol engines), Yanmar and Kohler (diesel engines) have great reputation for performance and reliability.

Single stage

The Blazemaster single stage pumps are designed specifically to move more water, more economically. They are ideal all purpose, hardworking pumps for a range of applications.

Twin stage

The Twin stage Fire Fighting pump provides higher pressure, allowing you to fight fires from a safer distance.

Often getting power to a site near a bore, creek, river or dam is difficult or even impossible. For all those situations, Onga offers the engine driven versions of its dependable cast iron jet and centrifugal pumps.

Coupled to shallow or deep well injectors, these pumps can be adapted to almost any job, and deliver water where and when you need it without the exorbitant cost of running electrical lines.

384 Hi-Flo

The 384 Hi-Flo engine drive pump features an excellent combination of flow and pressure. It has a strong cast iron construction and re-prime capabilities of up to 4.5m. This is the ultimate solution for demanding water transfer, irrigation or tank filling applications.

Onga GP960

The GP960 self primes extremely quickly and moves larger volumes of water at lower pressures. It has a strong Honda 6.5HP engine, cast-iron, abrasion resistant impeller, built-in non-return valve, quick-fill priming port for easy priming and is ideal for water cartage.

Engine Driven Farmmaster pumps

Onga has also coupled engines to the legendary farmmaster OJ jet pumps offering access to water from bores, creeks and rivers where no electrical power is available. Ideal where greater suction depths are needed for sprinklers, tank filling, water transfer and stock watering.

THE ENGINE DRIVE RANGE IS AVAILABLE IN A WIDE RANGE OF PETROL, DIESEL, RECOIL AND ELECTRIC START MODELS.

POWERED by
HONDA



YANMAR

KOHLER



Nomenclature	RANGE	ENGINE SIZE	ENGINE MANUFACTURER	FEATURES
	B - BLAZEMASTER	55 - 5.5HP	H - HONDA	E - ELECTRIC START
	BM - BLAZEMASTER TWIN	65 - 6.5HP	BS - BRIGGS & STRATTON	R - ROLL FRAME
		90 - 9.0HP	Y - YANMAR	
		10 - 10.0HP	L - LONCIN	
			K - KOHLER	

PERFORMANCE

BLAZEMASTER SINGLE PETROL ENGINE FIRE FIGHTING SYSTEMS

- The Blazemaster single-stage pumps are designed to move more water, more economically.
- As the world's largest engine manufacturer, Honda offers more engine experience than anyone. A well-earned reputation for engine quality and performance.
- Honda GX Series engines have long been recognized as the industry leader in providing reliable, easy-starting and fuel efficient small engines.
- Honda's automatic mechanical decompression system is designed to give you quicker, easier starts. The system consists of an oil level sensor inside the crankcase. When the oil reaches a level that is too low for safe operation the engine stops automatically.
- Briggs and Stratton Intek™ I/C race-bred series engine for reliability, durability and performance.
- Manual and electric start options for versatility.
- Fuel tap with sediment bowl and sight glass for greater ease when checking fuel and servicing.
- Dual element air filter for cleaner operation.
- Polyethylene fuel tank for impact / corrosion resistance.
- 'Run sense' low oil protection to protect the engine from low oil failures and engine damage.



FEATURES

- Big pump body with raised suction port.
- Larger diameter impellers.
- CFD* designed hydraulic components.
- FEA* designed pump components.
- Inbuilt non-return valve.
- Easy access to non-return valve.
- Large diameter priming ports.
- Large raised handle.
- Cast Aluminium construction.

BENEFITS

- Better priming capability.
- Higher discharge head.
- Higher performance and efficiency.
- Higher strength with low weight.
- Assists priming performance.
- Quicker installation and service.
- Fast and easy priming set-up.
- Better ergonomics.
- Strength, durability and lightweight portability.

APPLICATIONS

- Firefighting
- Tank filling
- Water transfer
- Boom spraying
- Irrigation

B55H
B65H



B55BS
B65BS
B80BS
B10BS

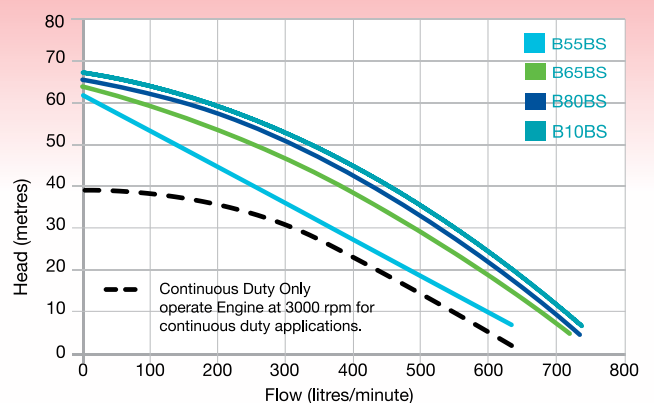
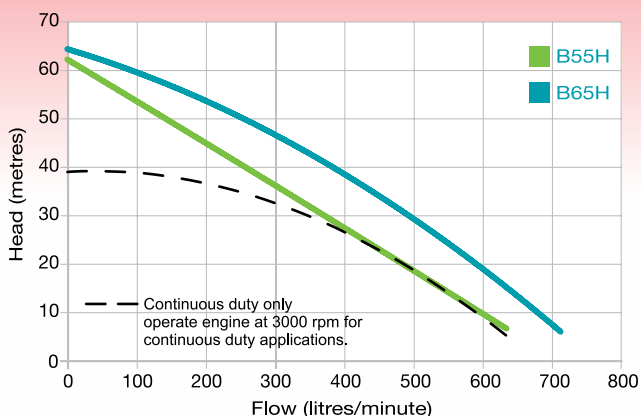

PERFORMANCE

BLAZEMASTER TWIN PETROL ENGINE FIRE FIGHTING SYSTEMS

- The Blazemaster Twin series are dual-impeller pumps designed to give you more pressure whilst delivering more water.
- Cast aluminium construction means strength, durability and lightweight portability.
- Big pump body with raised suction port for better priming capability.
- Larger diameter impellers providing higher discharge head.
- CFD (Computational Fluid Dynamics) designed hydraulic components means higher performance and efficiency.
- Honda's inner-vent carburettor places the float bowl vent on the "clean side" of the air filter elements so that the air/fuel ratio remains more constant as the elements become dirty. This allows the length of the service interval for air filter maintenance to be more than doubled.

POWERED by
HONDA



FEATURES

- Big pump body with raised suction port.
- Larger diameter impellers.
- CFD* designed hydraulic components.
- FEA* designed pump components.
- Inbuilt non-return valve.
- Easy access to non-return valve.
- Large diameter priming ports.
- Large raised handle.
- Cast Aluminium construction.

BENEFITS

- Better priming capability.
- Higher discharge head.
- Higher performance and efficiency.
- Higher strength with low weight.
- Assists priming performance.
- Quicker installation and service.
- Fast and easy priming set-up.
- Better ergonomics.
- Strength, durability and lightweight portability.

APPLICATIONS

- Firefighting
- Tank filling
- Water transfer
- Boom spraying
- Irrigation

BM55H
BM65H



BM55BS
BM65BS
BM80BS
BM10BS

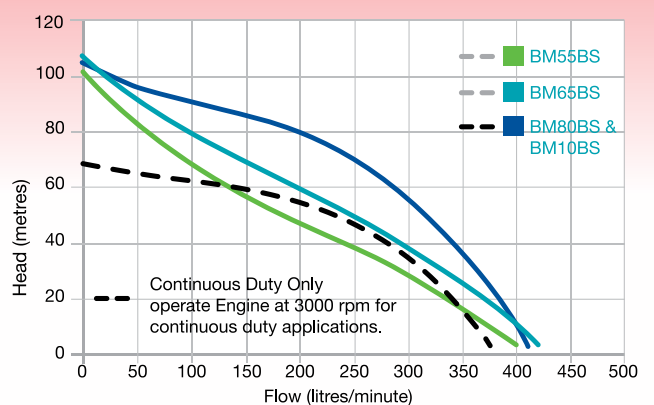
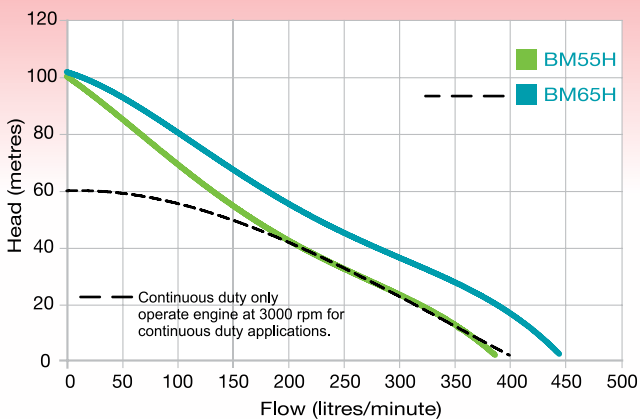

PERFORMANCE

BLAZEMASTER DIESEL

SINGLE AND TWIN STAGE DIESEL ENGINE FIRE FIGHTING SYSTEMS

The Blazemaster diesel are available in single and twin stage configuration for situations where more power is required to move large volumes of water quickly and efficiently.

APPLICATIONS:

- Firefighting
- Tank filling
- High flow water transfer
- Boom spraying
- Irrigation

YANMAR - EXCEEDING POWER AND ENVIRONMENTAL EXPECTATIONS.

To achieve the highest performing miniaturised and light weight diesel engines, Yanmar developed the L-N series single cylinder, air-single cylinder technologies. Designed with Yanmar's proprietary direct injection technology, maximum combustion efficiency is realised through the ideal match between the combustion chamber and injection system. This means that a powerful, but environmentally friendly engine.



KOHLER - WORLD CLASS ENGINEERING EXCELLENCE.

The diesel engine delivers the Performance Engineering standards you've come to expect from Kohler. The direct injection system produces increased power and lower fuel consumption. Full pressure lubrication offers superior cooling and performance combined with full-flow oil filters for longer engine and component life. Air cooling, horizontal shaft, single-cylinder design, and a cast iron liner set the standard for power and engineering excellence.



FEATURES:

- Compact, Direct Injection Technology.
- Quick and Easy Start.
- A little engine built to stand up to hard work.
- Fast, effortless starts from a one-pull recoil starter.
- The total FIE expertise only a complete diesel maker can provide.
- Durability.

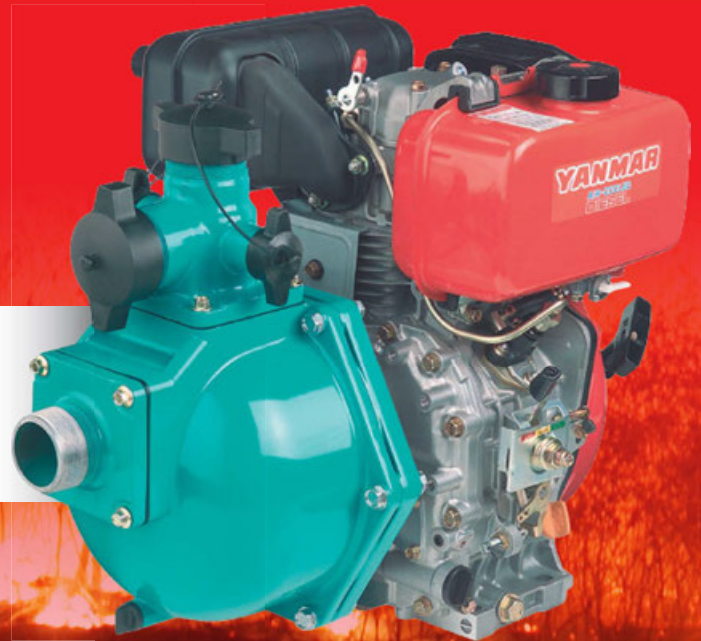

B48Y
B48K
B70Y BM70Y
B10YE BM10YE

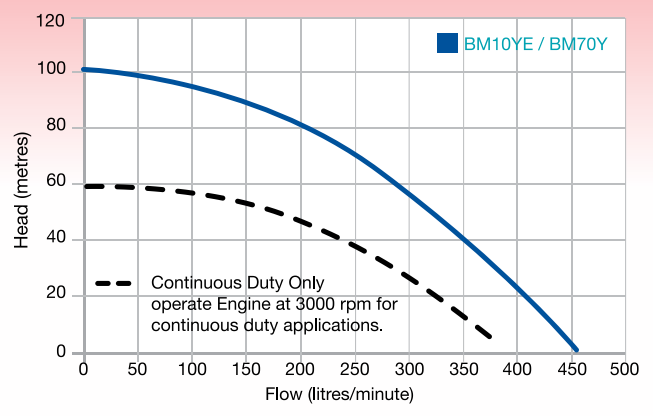
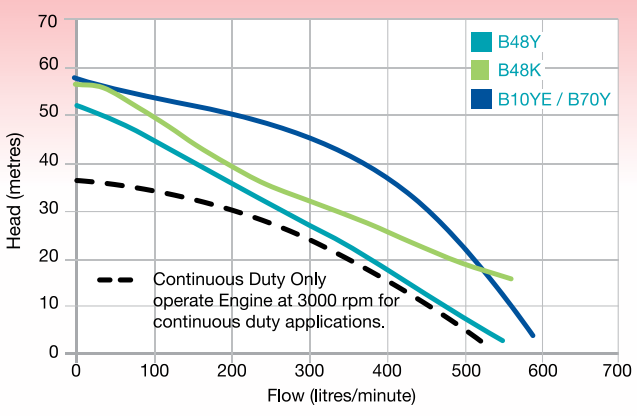

PERFORMANCE

BLAZEMASTER UTE PACKS

FULLY PORTABLE FIRE FIGHTING SYSTEMS

FIREPOD

A SELF CONTAINED FIRE FIGHTING RESOURCE OR WATER TRANSFER AID.

The ONGA Firepod is a fully portable and completely equipped four stroke petrol engine and pump combination with both suction and discharge hoses fitted that will provide a first line of attack to control ember attacks or spot fire outbreaks, as well as affording a general purpose portable water supply, transfer or irrigation source.

KIT INCLUDES:

- Blazemaster pump with Honda or Briggs & Statton engines.
- 400 litre polyethelene tank for impact/corrosion resistance.
- Barrel fire nozzle.
- Tool kit.



MINIBLAZE

LIGHTWEIGHT, EFFICIENT AND VERSATILE.

The MiniBlaze is perfect in situations where there is isolation from electrical power preventing electrical pumps being used. The MiniBlaze is equally at home helping plumbers and tradesman to evacuate water from work sites, farmers with remote stock watering, dust and amber supression. Versatility of the MiniBlaze is endless, from the handyman to river camp sites.

Available as a standalone unit or as a ute pack.

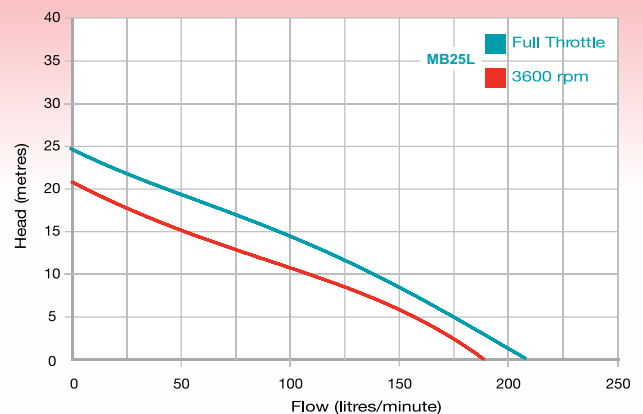

ENGINEMASTER CENTRIFUGAL

ENGINE DRIVEN WATER TRANSFER SYSTEMS

MODEL 384



- Hi-Flo centrifugal pump coupled to a Yanmar diesel or Honda / B&S petrol engine.
- All engines are available as electric start.
- Large 2" suction and discharge enables high head and high flow.
- Rugged cast iron construction for long life and durability.

APPLICATIONS:

- High flow water transfer.
- Tank filling.

GP960



- The Onga GP960 is a high volume 3" unit that can pump more than 1000 litres per minute.
- Available with a Honda or B&S petrol engine.
- Standard with 3" nylon nuts and tails for hose connection.
- Aluminium construction for strength and corrosion resistance.
- Cast iron open impeller provides excellent priming capabilities.
- Rotatable discharge port makes adaptable to site.
- Built-in non-return valve aids quick priming.
- Electric start options available.

APPLICATIONS:

- High flow water transfer and flood water evacuation.

MODEL	ENGINE	RE-PRIME (M)	SUCTION (BSP)	DISCHARGE (BSP)	PRIMING PORT (BSP)
384	7 HP diesel 8,9 or 10 HP petrol	4.5	2" F	2" F	3/4" F

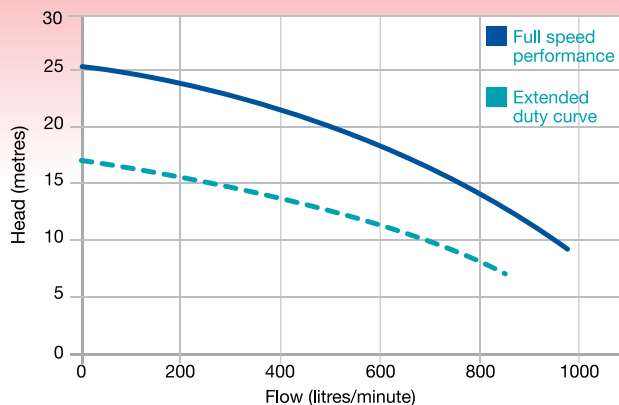
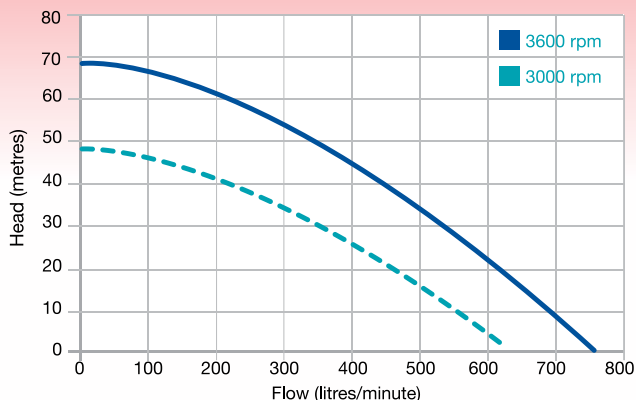

PERFORMANCE

ENGINEMASTER JET ASSISTED ENGINE DRIVEN WATER TRANSFER SYSTEMS

When your property needs a serious jet-assisted pump independent of electrical supply, only cast iron is good enough. Other materials just won't stand up to the extreme pressures common in engine driven jet assisted pumps. Combining the best jet pumps available with the most reliable engines results in the Onga OJ700E and OJ800E.

The OJ-E series gives you the flexibility to draw water from almost any source and location. You can rest assured that if your water supply changes, your OJ can change along with it — with over 40 injector combinations for the Onga Farmmaster range, there's a set-up to suit almost any application.

- Cast iron, heavy duty construction.
- Available with Honda and B&S petrol engines or Yanmar diesel engines.
- Available in shallow well or deep well configuration, with over 40 injector combinations.

APPLICATIONS:

- High suction lifts from dams, bores & rivers.
- Water transfer.
- Stock watering.
- Tank filling.
- Irrigation where high suction lifts are required.

OJ700E OJ700ES
OJ800E OJ800ES

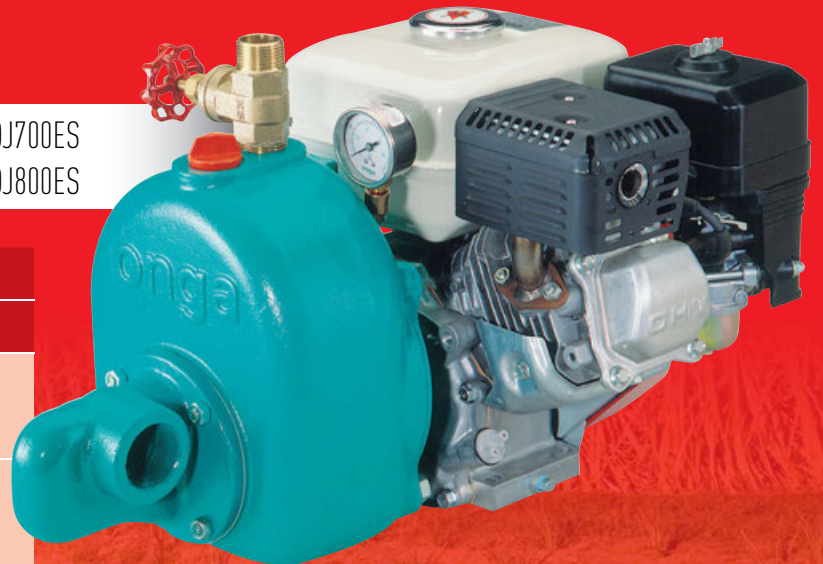

PETROL ENGINE DRIVE		
MODEL	ENGINE OPTIONS	HP
OJ700E	Honda / B&S	5.5 / 6.0
OJ700ES		
OJ800E	Honda / B&S	9.0 / 8.0
OJ800ES		
DIESEL ENGINE DRIVE		
OJ700E	Yanmar L-48	4.8
OJ800E	Yanmar L-70	7.0
OJ800ES	Yanmar L-70 e/start	7.0

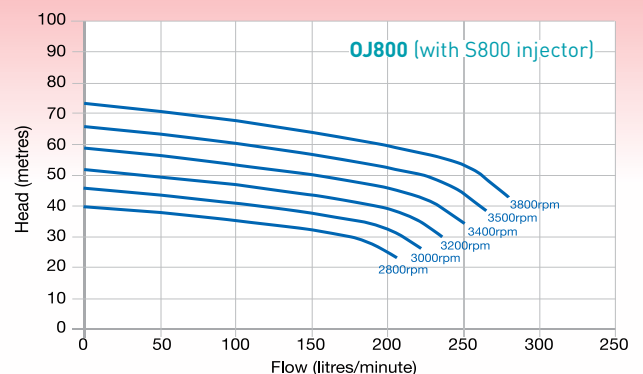
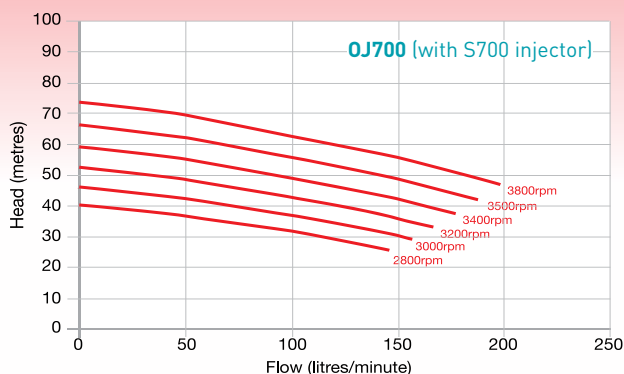

Based on S801 injector.

BLAZEMASTER

ENGINE DRIVEN FIRE FIGHTING SYSTEMS

BLAZEMASTER

Single impeller

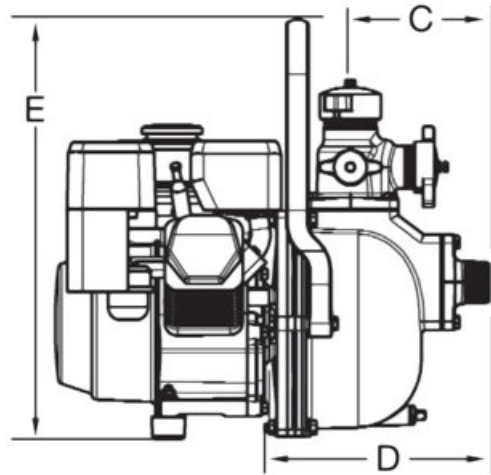
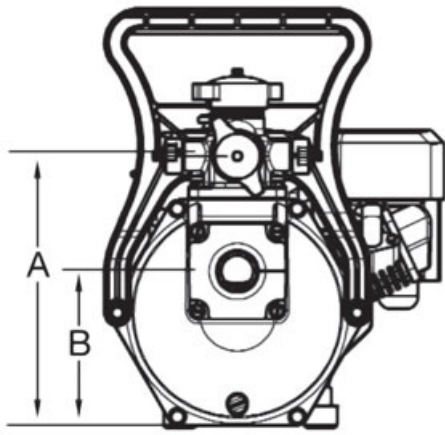

DIMENSIONS TABLE

PUMP MODEL	ENGINE MAKE	ENGINE HP	A	B	C	D	E	PUMP WEIGHT (Kg)
B55H	Honda GX160	5.5 HP	312	178	166	253	480	22.2
B65H	Honda GX200	6.5 HP	312	178	166	253	480	23.2
B90H	Honda GX270	9.0 HP	316	182	166	271	484	32.2
B48Y	Yanmar L48AE	4.8 HP	320	185	166	271	180	31.2
B70Y	Yanmar L70AE	7.0 HP	327	193	166	271	495	38.2
B70YE	Yanmar L70AE	7.0 HP E/S	327	193	166	271	495	45.2
B10YE	Yanmar L100AE	10.0 HP E/S	337	203	166	271	505	60.2

BLAZEMASTER

Twin impeller

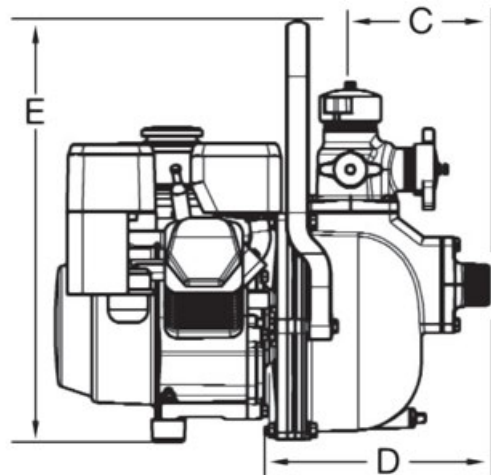
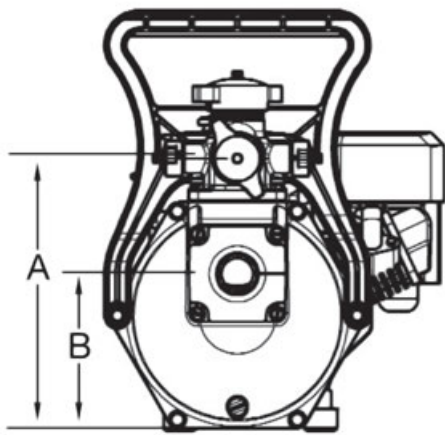

DIMENSIONS TABLE

PUMP MODEL	ENGINE MAKE	ENGINE HP	A	B	C	D	E	PUMP WEIGHT (Kg)
BM55H	Honda GX160	5.5 HP	312	178	166	253	480	22.2
BM65H	Honda GX200	6.5 HP	312	178	166	253	480	23.9
BM90H	Honda GX270	9.0 HP	316	182	166	271	484	33.1
BM70Y	Yanmar L70AE	7.0 HP	327	193	166	271	495	41.1
BM70YE	Yanmar L70AE	7.0 HP E/S	327	193	166	271	495	46.1
BM10YE	Yanmar L100AE	10.0 HP E/S	337	203	166	271	505	61.1

Note: Unless otherwise specified, all dimension in mm.

ENGINEMASTER

ENGINE DRIVEN WATER TRANSFER SYSTEMS

384 HI-FLO

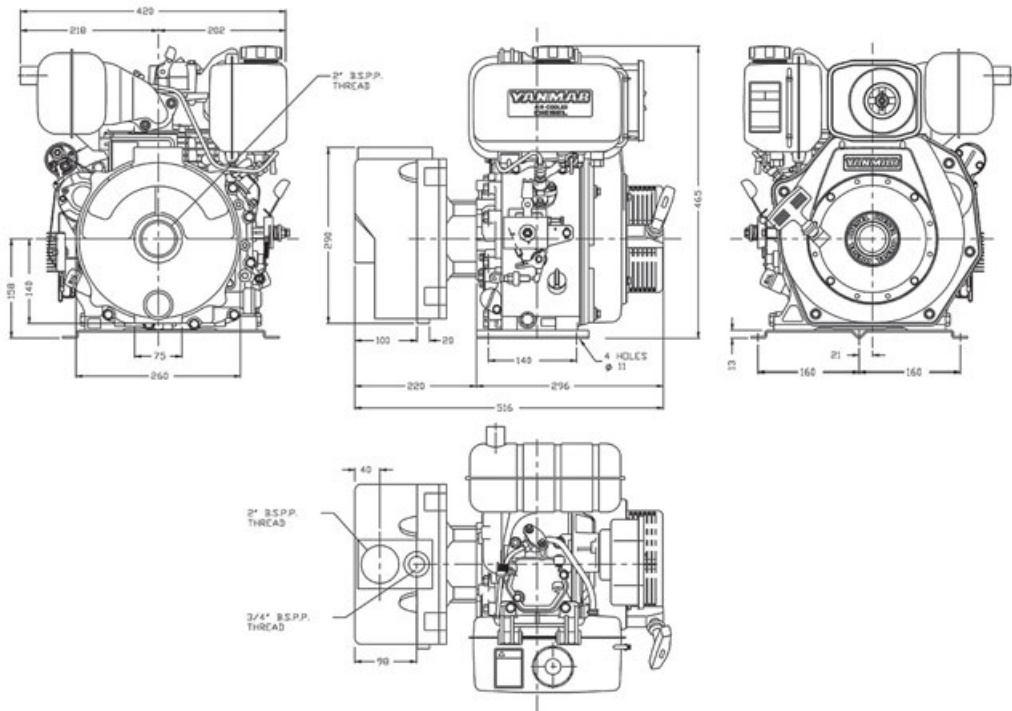

GP960

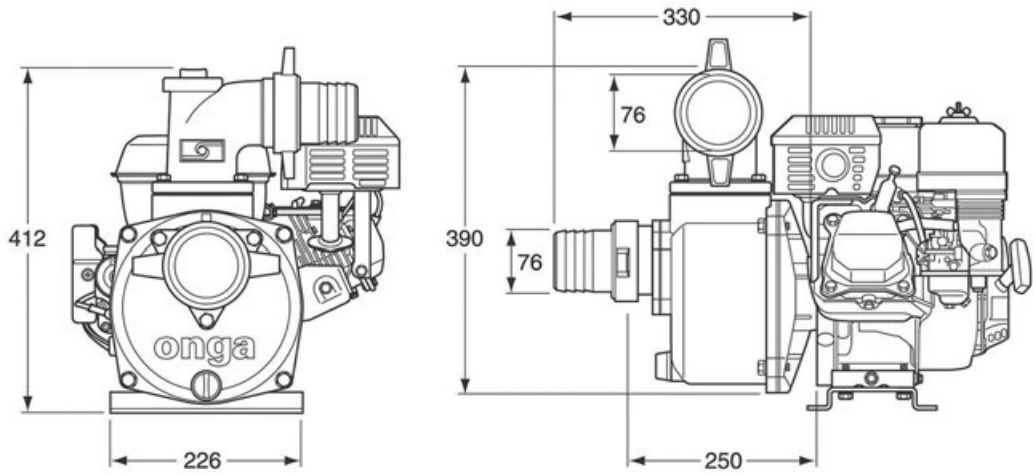

OJ700E - OJ800E

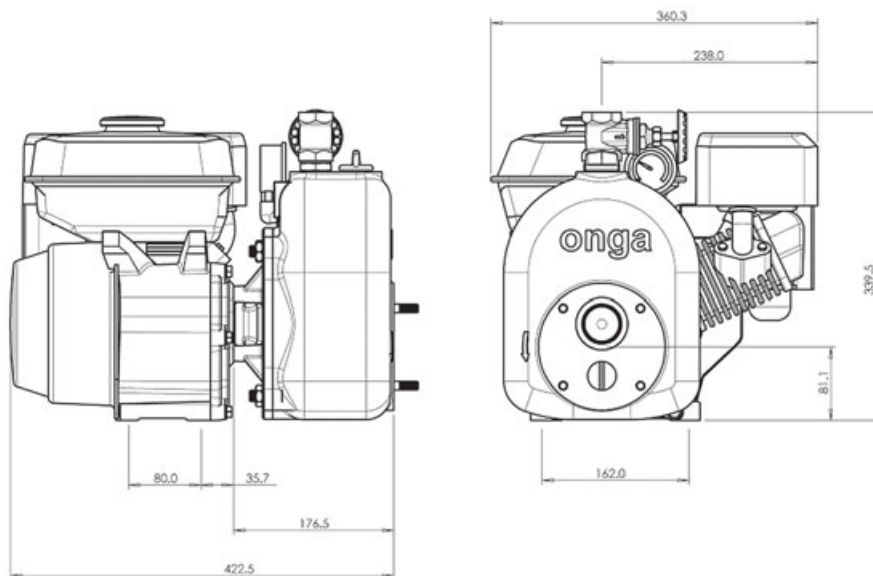

BLAZEMASTER

ENGINE DRIVEN FIRE FIGHTING SYSTEMS

MATERIALS of
CONSTRUCTION

COMPONENT	MODEL
	BLAZEMASTER SERIES
PUMP CASING	POWDER COATED ALUMINIUM
IMPELLER (S)	30% GLASS FILLED NYLON
DIFFUSER	ALUMINIUM
MOTOR SHAFT	MILD STEEL
O-RING	NITRILE
MECHANICAL SEAL	CARBON / CERAMIC
NUTS & TAILS	POLYPROPYLENE

TECHNICAL
DATA

MODEL	HP NOMINAL	ENGINE MODEL	SUCTION (BSP) MALE	3 WAY DISCHARGE (BSP) MALE	OPTIONAL EXTRAS*
BLAZEMASTER SINGLE STAGE PETROL ENGINE MODELS - HONDA					
B55H	5.5	HONDA GX160	1.5"	1", 1", 1.5"	B - RF
B65H	6.5	HONDA GX200	2.0"	1", 1", 2"	ES - RF
B90H	9.0	HONDA GX270	2.0"	1", 1", 2"	ES
BLAZEMASTER SINGLE STAGE PETROL ENGINE MODELS - BRIGGS & STRATTON					
B55BS	5.0	BRIGGS & STRATTON	1.5"	1", 1", 1.5"	RF
B65BS	6.0	BRIGGS & STRATTON	2"	1", 1", 2"	RF - ES
B80BS	8.0	BRIGGS & STRATTON	2"	1", 1", 2"	ES
B10BSE	10.0	BRIGGS & STRATTON	2"	1", 1", 2"	-
BLAZEMASTER SINGLE STAGE DIESEL ENGINE MODELS - YANMAR					
B48Y	4.8	YANMAR L48AE	1.5"	1", 1", 1.5"	-
B70Y	7	YANMAR L70AE	2.0"	1", 1", 2"	ES
B10YE	10	YANMAR L100AE	2.0"	1", 1", 2"	-
BLAZEMASTER TWIN DUAL STAGE PETROL ENGINE MODELS - HONDA					
BM55H	5.5	HONDA GX160	1.5"	1", 1", 1.5"	RF
BM65H	6.5	HONDA GX200	2.0"	1", 1", 2"	ES - RF
BM90H	9.0	HONDA GX270	2.0"	1", 1", 2"	ES
BLAZEMASTER TWIN DUAL STAGE PETROL ENGINE MODELS - BRIGGS & STRATTON					
BM55BS	5.0	BRIGGS & STRATTON	1.5"	1", 1", 1.5"	RF
BM65BS	6.0	BRIGGS & STRATTON	2"	1", 1", 2"	RF & ES
BM80BS	8.0	BRIGGS & STRATTON	2"	1", 1", 2"	ES
BM10BSE	10.0	BRIGGS & STRATTON	2"	1", 1", 2"	-
BLAZEMASTER TWIN DUAL STAGE DIESEL ENGINE MODELS - YANMAR					
BM70Y	7	YANMAR L70AE	2.0"	1", 1", 2"	ES
BM10YE	10	YANMAR L100AE	2.0"	1", 1", 2"	-
*OPTIONAL EXTRAS: B - Boom spray ES - Electric start RF - Roll frame					

POWERED by
HONDA



YANMAR

ENGINEMASTER

ENGINE DRIVEN WATER TRANSFER SYSTEMS

MATERIALS of
CONSTRUCTION

COMPONENT	MODEL		
	GP960	384	OJ SERIES
PUMP CASING	POWDER COATED ALUMINIUM	COATED CAST IRON	COATED CAST IRON
IMPELLER (S)	CAST IRON	POLYCARB. 20% GLASS FILLED	POLYCARB. 20% GLASS FILLED
DIFFUSER	CAST IRON	NORYL	NORYL
MOTOR SHAFT	MILD STEEL	MILD STEEL	MILD STEEL
O-RING	NITRILE	NITRILE	NITRILE
MECHANICAL SEAL	CARBON / CERAMIC	CARBON / CERAMIC	CARBON / CERAMIC
NUTS & TAILS	POLYPROPYLENE	N/A	N/A

TECHNICAL
DATA

MODEL	PART NUMBER	HP NOMINAL	ENGINE MODEL	SUCTION	DISCHARGE
HIGH VOLUME PETROL ENGINE DRIVE MODELS - HONDA					
GP960	333314	6.5	HONDA GX200	3"	3"
GP960E	333317	6.5	HONDA GX200ES	3"	3"
HIGH VOLUME PETROL ENGINE DRIVE MODELS - BRIGGS & STRATTON					
GP960	333315	6.0	BRIGGS & STRATTON	3"	3"
GP960E	333318	6.0	BRIGGS & STRATTON	3"	3"
HIGH FLOW PETROL ENGINE DRIVE MODELS - HONDA					
384	338425	9	HONDA GX270	2" (F)	2" (F)
384	338426	9	HONDA GX270ES	2" (F)	2" (F)
HIGH FLOW PETROL ENGINE DRIVE MODELS - BRIGGS & STRATTON					
384	338427	8.0	BRIGGS & STRATTON	2"	2" (F)
384	338428	8.0	BRIGGS & STRATTON ES (electronic start)	2"	2" (F)
384	338429	10.0	BRIGGS & STRATTON	-	-
HIGH FLOW DIESEL ENGINE DRIVE MODELS - YANMAR					
384	338411	7	YANMAR L70AE	2" (F)	2" (F)
384	338410	7	YANMAR L70AE ES (electronic start)	2" (F)	2" (F)
JET ASSISTED ENGINE DRIVE MODELS - HONDA					
OJ700E	110075	5.5	HONDA GX160	1½" (F)	1" (F)
OJ800E	110160	9	HONDA GX270	1½" (F)	1" (F)
OJ800ES	110161	9	HONDA GX270ES	1½" (F)	1" (F)
JET ASSISTED ENGINE DRIVE MODELS - BRIGGS & STRATTON					
OJ700E	110079	6.0	BRIGGS & STRATTON	1½" (F)	1" (F)
OJ700ES	110080	6.0	BRIGGS & STRATTON	1½" (F)	1" (F)
OJ800E	110162	8.0	BRIGGS & STRATTON	1½" (F)	1" (F)
OJ800ES	110163	8.0	BRIGGS & STRATTON	1½" (F)	1" (F)
JET ASSISTED DIESEL ENGINE DRIVE MODELS - YANMAR					
OJ700E	110167	4.8	YANMAR L48AE	1½" (F)	1" (F)
OJ800E	110168	7	YANMAR L70AE	1½" (F)	1" (F)
OJ800ES	110169	7	YANMAR L70AE ES (electronic start)	1½" (F)	1" (F)

NOTE: For technical information on the engines, contact engine manufacturer.

POWERED by
HONDA



YANMAR

TECHNICAL
INJECTOR SIZING

ENGINEMASTER JET ASSISTED

ENGINE DRIVEN WATER TRANSFER SYSTEMS

OJ700 Shallow well	INJECTOR MODEL	PRESSURE SWITCH SETTING (kPa)	SUCTION LIFT (M)	DISCHARGE HEAD (M)														MAXIMUM PUMP PRESSURE (kPa)
				15	21	27	34	40	46	52	58	64	70	76	82	88	95	
				CAPACITY (LPM)														
S700#	210-350#	0	0	162	159	138	80	27										430
		3	0	130	127	110	64											400
		6	0	92	91	79	46											370
		7.6	0	65	64	55	32											355
S701*	280-455	0				114	94	61	31									540
		3				91	75	49	25									510
		6				65	54	35	18									480
		7.6				46	38	24	12									465
S702*	350-560	0						85	66	42	24							635
		3						68	53	34	19							605
		6						48	38	24	14							575
		7.6						34	26	17	10							560
S703**	420-630	0						69	50	35	22							690
		3						55	40	28	18							660
		6						39	29	20	13							630
		7.6						28	20	14	9							615
S704**	490-700	0						56	51	39	28	18	11					800
		3						45	41	31	22	14	9					770
		6						32	29	22	16	10						740
		7.6						22	20	16	11	7						725
OJ800 Shallow well	INJECTOR MODEL	PRESSURE SWITCH SETTING (kPa)	SUCTION LIFT (M)	DISCHARGE HEAD (M)														MAXIMUM PUMP PRESSURE (kPa)
				15	21	27	34	40	46	52	58	64	70	76	82	88	95	
				CAPACITY (LPM)														
S800#	210-350#	0	0	245	241	218	156	72										430
		3	0	196	193	174	125											400
		6	0	140	137	124	89											370
		7.6	0	98	96	87	62											355
S801*	280-455	0				215	204	160	116	66								525
		3				172	163	128	93	53								495
		6				123	116	91	66									465
		7.6				86	82	64	46									450
S802*	350-560	0				154	150	117	85	54	25							635
		3				123	120	94	68	43	20							605
		6				88	86	67	48	31								575
		7.6				62	60	47	34	22								560
S803*	420-630	0						112	88	64	42	25						730
		3						90	70	51	34	20						700
		6						64	50	36	24	14						670
		7.6						45	35	26	17	10						655
S804**	490-700	0						90	67	47	31	18						800
		3						72	54	38	24	14						770
		6						51	38	27	18	10						740
		7.6						36	27	19	12	7						725
S805**	630-840	0							70	57	43	31						970
		3							56	46	34	25	17					880
		6							40	32	25	18	12					850
		7.6							28	23	17	12	8					835
S806**	770-1050	0											34	33	30	25	18	1145
		3											27	26	24	20	14	1115
		6											19	18	17	14	10	1085
		7.6											14	13	12	10	7	1070

Factory pressure switch setting.

* Pressure switch adjustment needed.

+ 700248 pressure switch needed for extra high pressure switching.
Pump suction 1 1/2" BSP Female.

Pump discharge port 1" BSP Female (pump), 1" BSP Female (pressure kit).

Both single and three phase models available.

TECHNICAL
INJECTOR SIZING

ENGINEMASTER JET ASSISTED

ENGINE DRIVEN WATER TRANSFER SYSTEMS

OJ700 Deep well	INJECTOR MODEL	PRESSURE SWITCH SETTING (kPa)	INJECTOR SIZE (INCH)	SUCTION PIPE (INCH)	PRESSURE PIPE (INCH)	BORE WATER PUMPING LEVEL OR SUCTION LIFT (M)														MIN. PUMP PRESS. (kPa)	MAX. PUMP PRESS. (kPa)
						6	9	12	15	18	21	24	27	30	34	37	40				
						CAPACITY (LPM)															
D414	210-350	3 ¼	1 ¼	1	90	78	60													186	455
D415	210-350	-	-	1				40	30	28	18	15								186	483
D514	210-350	3 ¾	-	1 ¼	120	105	75	63												179	469
D515	210-350	-	1 ½	1 ¼					50	40	30									193	483
D516	210-350	-	-	-											28	20	13	10		193	455
D611	210-350	#4 ¾	-	-	135	120	113	90												179	462
D612	210-350	-	2	1 ½					68	60	48									186	483
D613	210-350	-	-	-											54	35	25	25	15	193	518

OJ800 Deep well	INJECTOR MODEL	PRESSURE SWITCH SETTING (kPa)	INJECTOR SIZE (INCH)	SUCTION PIPE (INCH)	PRESSURE PIPE (INCH)	BORE WATER PUMPING LEVEL OR SUCTION LIFT (M)														MIN. PUMP PRESS. (kPa)	MAX. PUMP PRESS. (kPa)	
						6	9	12	15	18	21	24	27	30	34	37	40	43	46			49
						CAPACITY (LPM)																
D520	210-350* or 280-480	3 ¾	1 ½	1 ¼	160	135	113	85												248	573	
D518	210-350* or 280-480	-	-	-					63	58	43									262	690	
D519	210-350* or 280-480	-	-	-									38	30	23	18	15			262	656	
D618	210-350* or 280-480	#4 ¾	-	-	205	173	150													214	517	
D619	210-350* or 280-480	-	2	1 ½					125	100	85									242	600	
D616	210-350* or 280-480	-	-	-									68	60	50					276	711	
D617	210-350* or 280-480	-	-	-											48	40	33	28	25	20	276	662

All performances are @2850RPM.

#Special injectors are available to fit down 4" PVC pipe.

Maximum pump pressure = @ minimum suction lift per injector.

HOW TO SELECT AND INSTALL CONVERTIBLE JET PUMPS

ENGINEMASTER JET ASSISTED ENGINE DRIVEN WATER TRANSFER SYSTEMS

Less < than 7.6m

DETERMINE TOTAL SUCTION
(including suction line losses)

Greater > than 7.6m

SHALLOW WELL JET PUMP

SUBMERSIBLE BOREHOLE OR DEEP WELL

DEEP WELL JET PUMP

See Submersible Borehole Distributor Catalogue

Customer site data:

- Water depth. This added to friction losses through footvalve and suction line give total suction head (0-7.6m)
- Discharge head pressure required (m or kPa) - This includes pressure required by the application, friction loss from delivery to usage points, and height differences.
- Volume required (l/m)

Using the Shallow Well Jet Pump selection table (page 16), select the pump and injector combination that delivers the right flow at the design suction and delivery heads.



Install the pump with foot valve or check valve, suction line, injector and pressure tank. Adjust the pressure switch to suit the application and injector fitted.

Deep Well Jet Pumps are more suitable than submersible pumps where the following conditions may exist:

Depths down to 49 metres, corrosive water, sandy water, low or variable flow rates,.

Customer site data:

- Water depth. Suction pipe sizes are given for each injector, and performance shown in the tables takes this friction loss into account.
- Discharge head pressure required (m or kPa) - This includes pressure required by the application, friction loss from delivery to usage points, and height differences. Total delivery head must be converted to kPa.

Using the Deep Well Jet Pump selection table (page 17), select the pump and injector combination that delivers the right flow at the design suction and delivery heads. The operating pressure must be maintained above the minimum injector pressure.



Install the pump and injector using correctly sized pipes. The injector must be installed at least 3m below water level. Adjust the pressure switch to suit the application and injector fitted. Adjust the gate valve to ensure that minimum operating pressure is maintained.



BLAZEMASTER

ENGINE DRIVEN FIRE FIGHTING SYSTEMS

BLAZEMASTER SINGLE

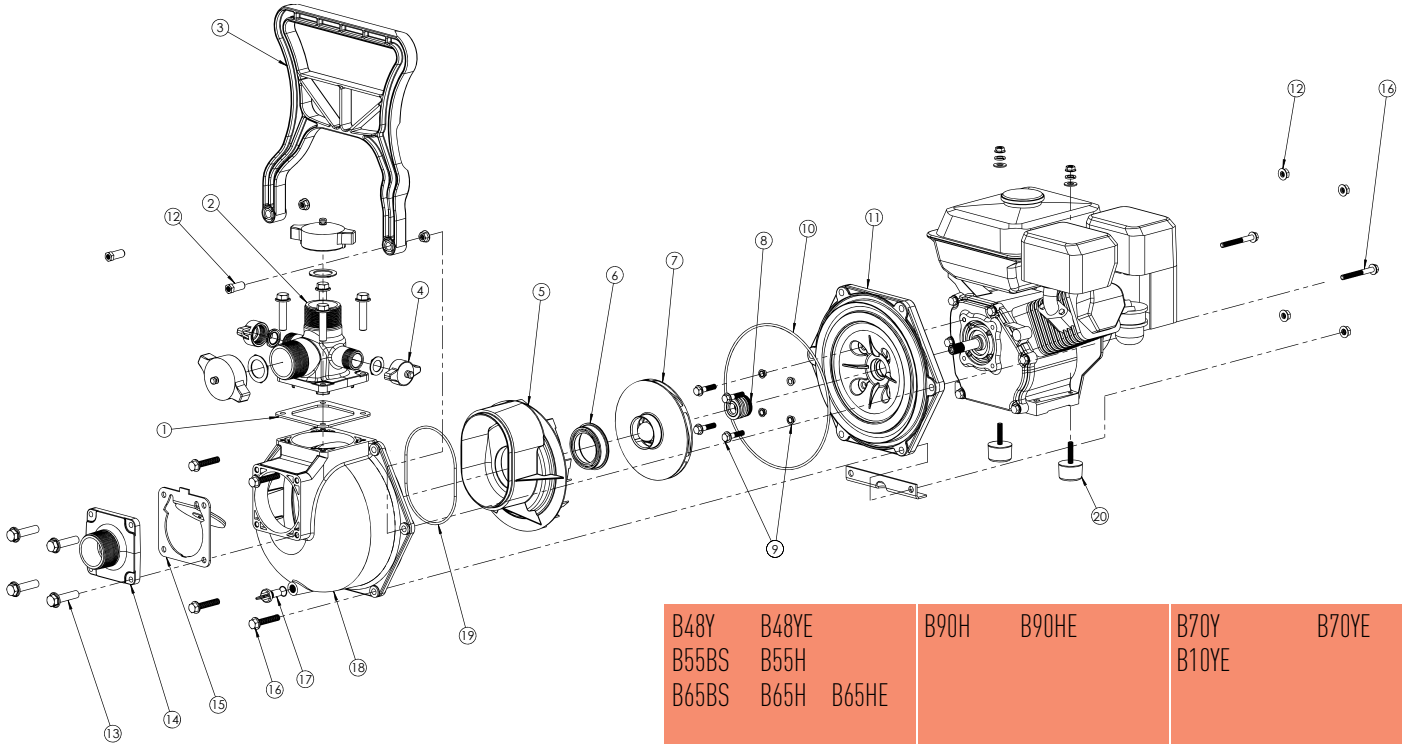

B48Y	B48YE		B90H	B90HE		B70Y	B70YE
B55BS	B55H					B10YE	
B65BS	B65H	B65HE					

REF NO.	COMPONENT DESCRIPTION	PART NO.		PART NO.		PART NO.	
1	GASKET - DISCHARGE	510960K	1PC	510960K	1PC	510960K	1PC
2	FLANGE - DISCHARGE 1½" BSP	410933G	1PC	-	1PC	-	1PC
	FLANGE - DISCHARGE 2" BSP	-	1PC	410943G	1PC	410943G	1PC
3	HANDLE	305590	1PC	-	1PC	-	1PC
4	CAP & WASHER 1" BSP	800111	2PC	800111	2PC	800111	2PC
	CAP & WASHER 1 ¼" BSP	800112	2PC	-	2PC	-	2PC
	CAP & WASHER 2" BSP	800382	2PC	800382	2PC	800382	2PC
5	DIFFUSER	411420	1PC	411420	1PC	411420	1PC
6	WEAR RING	510970K	1PC	510980K	1PC	510980K	1PC
7	IMPELLER- 5/8" SHAFT	511070K	1PC	-	1PC	-	1PC
	IMPELLER - 1" SHAFT	-	1PC	511210K	1PC	511210K	1PC
8	MECHANICAL SEAL	801428	1PC	700274K	1PC	700274K	1PC
	OVERHAUL KIT (1,4,8,10,15 & 19)	801244	1PC	801244	1PC	-	1PC
	VITON SEAL & O-RING KIT	801364K	1PC	801365K	1PC	801365K	1PC
9	BOLT & SEAL KIT (PK/12)	800273K	1PC	800273K	1PC	800273K	1PC
10	O-RING CASING	702216K	1PC	702216K	1PC	702216K	1PC
11	YOKE ¾" BLAZEMASTER	305494G	1PC	-	1PC	-	1PC
	YOKE 1" BLAZEMASTER	-	1PC	305503G	1PC	305503G	1PC
12	NUTS - CASING (PK/12)	800092K	6PC	800092K	6PC	800092K	6PC
13	SCREW M8 (PK/8)	702771K	8PC	702771K	8PC	702771K	8PC
14	FLANGE - SUCTION 1 1/2" BSP (5.5HP)	410853G	1PC	-	1PC	-	1PC
	FLANGE - SUCTION 2" BSP (Larger)	410863G	1PC	410863G	1PC	410863G	1PC
15	GASKET - CLACKER ASSY.	511150	1PC	511150	1PC	511150	1PC
16	CASING BOLTS	702639	1PC	702639	1PC	702639	1PC
17	PLUG ¼" DRAIN (INC. O-RING)	800222	1PC	800222	1PC	800222	1PC
18	CASING	305483G	1PC	305483G	1PC	305483G	1PC
19	O-RING DIFFUSER	705901K	1PC	705901K	1PC	705901K	1PC
20	ANTI VIVRATION FEET (SET/2)	801356K	1PC	-	1PC	-	1PC
21	BRACKET SUPPORT	608960	1PC	-	1PC	-	1PC
NS	ROLL FRAME (SMALL)	801372K	1PC	-	1PC	-	1PC
NS	ROLL FRAME (LARGE)	-	1PC	801373K	1PC	801373K	1PC
NS	HOSE KIT (1 1/2" SUCTION)	701124	1PC	-	1PC	-	1PC
NS	HOSE KIT (2" SUCTION)	701126	1PC	701126	1PC	701126	1PC

Drawings are indicative only, product appearance may change slightly.

BLAZEMASTER

ENGINE DRIVEN FIRE FIGHTING SYSTEMS

BLAZEMASTER TWIN

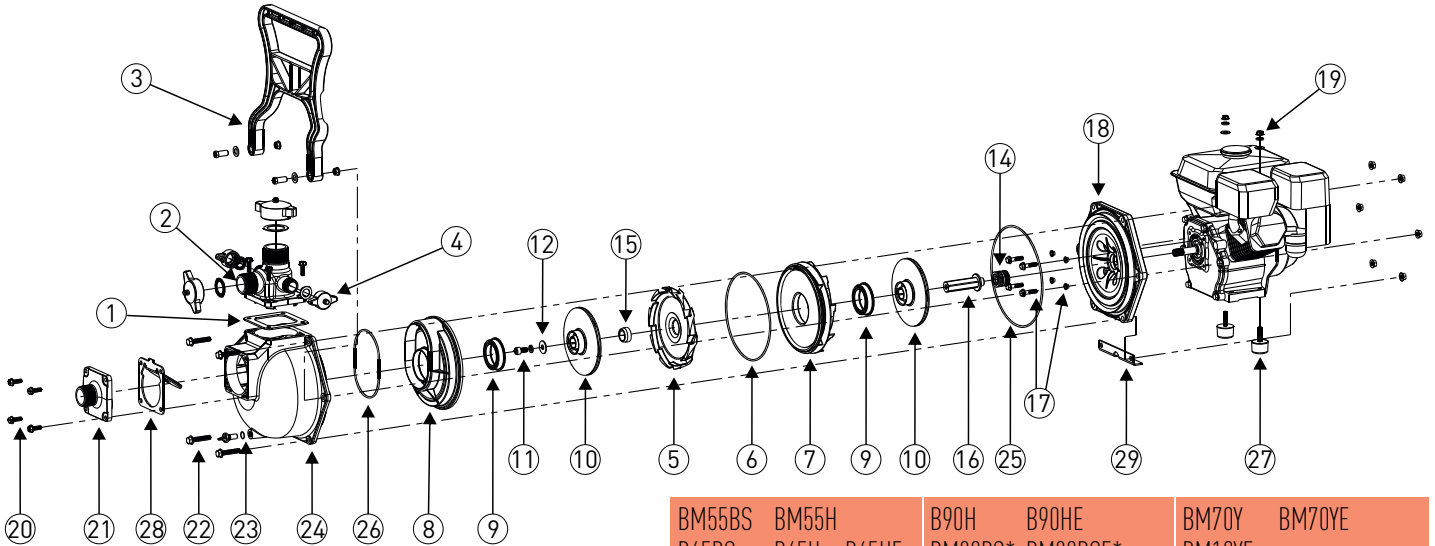

BM55BS B65BS	BM55H B65H	B65HE	B90H BM80BS* BM10BSE*	B90HE BM80BSE*	BM70Y BM10YE	BM70YE
-----------------	---------------	-------	-----------------------------	-------------------	-----------------	--------

REF NO.	COMPONENT DESCRIPTION	PART NO.	PART NO.	PART NO.	PART NO.	PART NO.
1	GASKET - DISCHARGE	510960K	1PC	510960K	1PC	510960K 1PC
2	FLANGE - DISCHARGE 1½" BSP	410933S	1PC	-	-	-
	FLANGE - DISCHARGE 2" BSP	-	-	410943S	1PC	410943S 1PC
3	HANDLE	305590	1PC	-	-	-
NS	NUT - BUSH HANDLE	609010K	1PC	-	-	-
	CAP & WASHER 1" BSP	800111	2PC	800111	2PC	800111 2PC
4	CAP & WASHER 1½" BSP	800112	AR	-	-	-
	CAP & WASHER 2" BSP	800382	AR	800382	AR	800382 AR
5	DIFFUSER - INTERSTAGE	305538	1PC	305538	1PC	305538 1PC
6	O-RING DIFFUSER - INTERSTAGE	702261K	1PC	702261K	1PC	702261K 1PC
7	DIFFUSER - 2ND STAGE	305515	1PC	305515	1PC	305515 1PC
8	SUCTION COVER	305555	1PC	305555	1PC	305555 1PC
9	WEAR RING	510970K	2PC	510980K	2PC	510980K 2PC
10	IMPELLER - 5/8" SHAFT	511050K	2PC	-	-	-
	IMPELLER - 1" SHAFT	-	-	511060K	2PC	511060K 2PC
11	IMPELLER - SCREW	801367K	1PC	801367K	1PC	801367K 1PC
	IMPELLER WASHER M10 x 30	801367K	1PC	801367K	1PC	801367K 1PC
	IMPELLER WASHER M10 x 40	-	-	801367K	1PC	801367K 1PC
13	WASHER SPRING - IMPELLER	801367K	1PC	801367K	1PC	801367K 1PC
NS	OVERHAUL KIT 3/4" [1,4,8,10,15 & 19]	801244	1PC	-	-	-
14	MECHANICAL SEAL KIT	801428	1PC	700270K	1PC	700270K 1PC
NS	VITON SEAL KIT ¾"	801364K	1PC	-	-	-
	VITON SEAL KIT 1"	-	-	801365K	1PC	801365K 1PC
15	SPACER SLEEVE 5/8" & ¾" SHAFT	608770K	1PC	-	-	-
	SPACER SLEEVE 1" SHAFT	-	-	608780K	1PC	608780K 1PC
16	STUB SHAFT 5/8"	608930K	1PC	-	-	-
	STUB SHAFT 1"	-	1PC	608950K	1PC	608950K 1PC
17	BOLT & SEAL KIT (Set/12)	800273K	1PC	800273K	1PC	800273K 1PC
18	YOKE ¾" BLAZEMASTER	305494S	1PC	-	-	-
	YOKE 1" BLAZEMASTER	-	-	305503S	1PC	305503S 1PC
19	NUTS - CASING	800092K	6PC	800092K	6PC	800092K 6PC
20	SCREW (PK/6) M8	702771K	1PC	702771K	1PC	702771K 1PC
21	FLANGE - SUCTION 1½" BSP	410853S	1PC	-	-	-
	FLANGE - SUCTION 2" BSP	-	-	410863S	1PC	410863S 1PC
22	BOLTS - CASING	702639	6PC	702639	6PC	702639 6PC
23	PLUG ¼" DRAIN (INC. O-RING)	800222	1PC	800222	1PC	800222 1PC
24	CASING	305483S	1PC	305483S	1PC	305483S 1PC
25	CASING O-RING	702806	2PC	-	-	-
26	O-RING SUCTION COVER	705901K	1PC	705901K	1PC	705901K 1PC
27	ANTI VIBRATION FEET (SET/2)	801356K	1PC	-	-	-
28	GASKET - CLACKER ASSY.	511150	1PC	511150	1PC	511150 1PC
29	BRACKET SUPPORT	608960	1PC	608460*	1PC	-
NS	ROLL FRAME (LARGE)	801373K	1PC	-	-	-
NS	FIRE FIGHTING HOSE KIT (1 1/2" SUCTION)	701124	1PC	-	-	-
NS	FIRE FIGHTING HOSE KIT (2" SUCTION)	-	-	701126	1PC	701126 1PC

18 Drawings are indicative only, product appearance may change slightly.

BLAZEMASTER

ENGINE DRIVEN FIRE FIGHTING SYSTEMS

MINIBLAZE

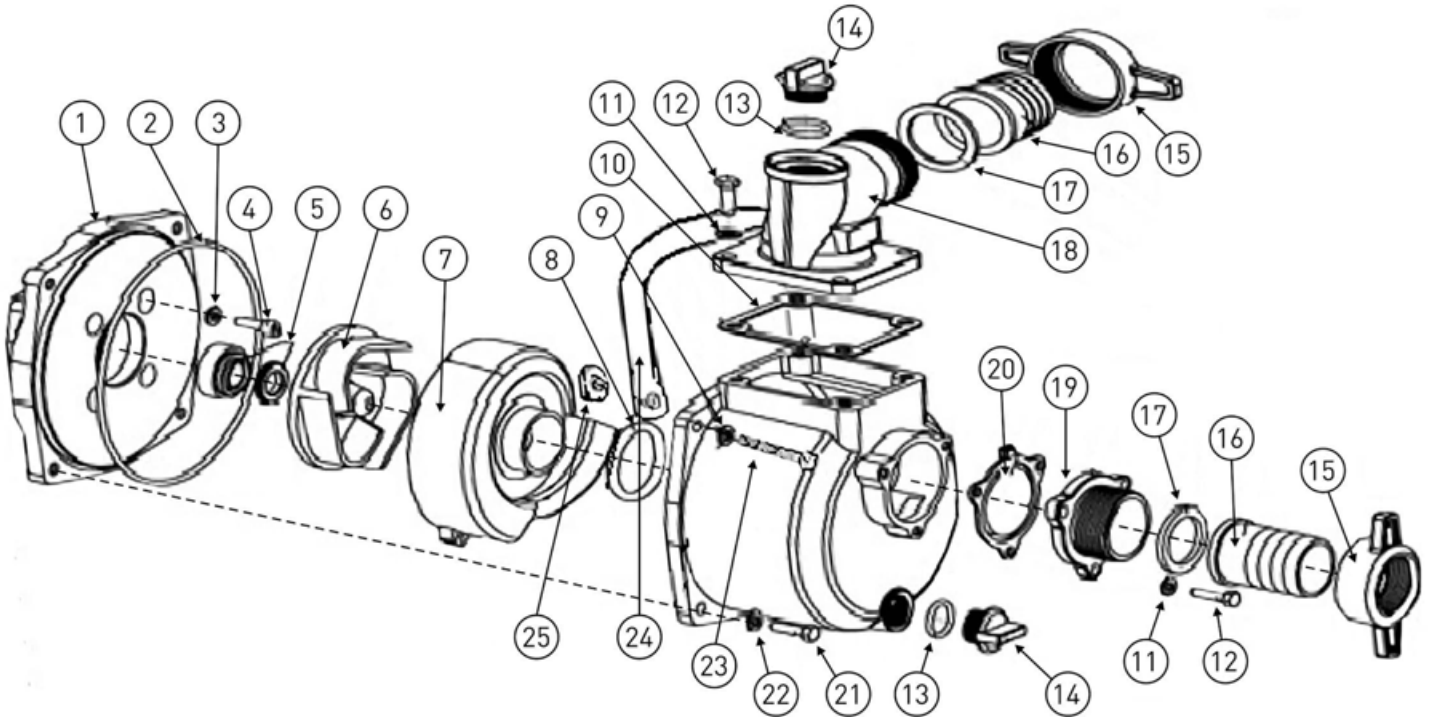

MB25L	REF NO.	COMPONENT DESCRIPTION	PART NO.	
	3	WASHER SEALING		4PC
	4	SOCKET HEAD CAP SCREW		4PC
	11	WASHER (6X13X1.2)		7PC
	12	BOLT (M6X18)	NUT & BOLT KIT	7PC
	21	BOLT (M8X20)	707560	2PC
	22	WASHER (8X16X1.2)		4PC
	23	BOLT (M8X40)		2PC
	25	NUT, FLANGE (M8)		2PC
	2	O'RING DIFFUSER		1PC
	5	MACHINERY SEAL		1PC
	8	O'RING	SEAL & O'RING KIT	1PC
	10	FLANGE OUTPUT	707558	1PC
	13	O'RING		2PC
	20	CHECK VALVE		1PC
	10	FLANGE OUTPUT		1PC
	13	O'RING		2PC
	14	PLUG	SUCTION & DISCHARGE KIT	2PC
	18	FLANGE OUTPUT	707559	1PC
	19	FLANGE ENDURE PRESS		1PC
	20	CHECK VALVE		1PC
	6	IMPELLER	660200010-T850	1PC
	NS	AIR CLEANER ASSEMBLY	180020323-T010	1PC
	NS	CARBURETOR	170020440-T010	1PC
	NS	FAN COVER ONLY	160210004-T010	1PC
	NS	FUEL TANK	170500514-T010	1PC
	NS	IGNITION ASSEMBLY	270920171-T010	1PC
	NS	OIL SENSOR	281850155-T010	1PC
	NS	RECOIL START & FAN COVER	193490001-T010	1PC
	NS	SPARK PLUG	270960027-T010	1PC
	NS	SWITCH ENGINE STOP	271660031-T010	1PC
	NS	WET END KIT COMPLETE	660180028-T850	1PC

384

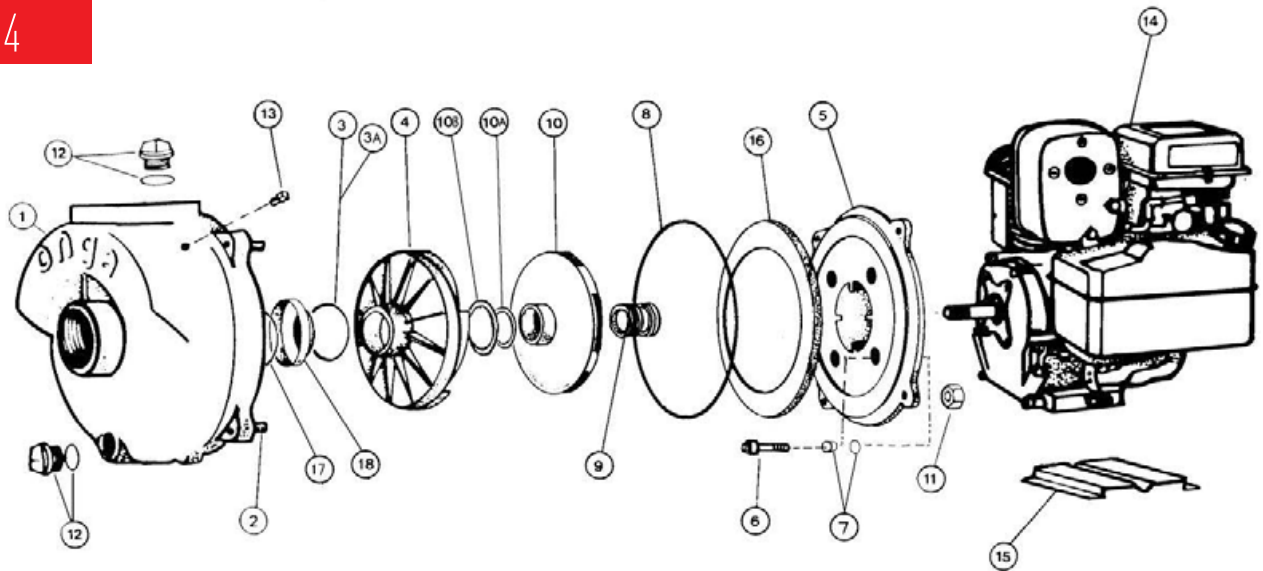

GP960

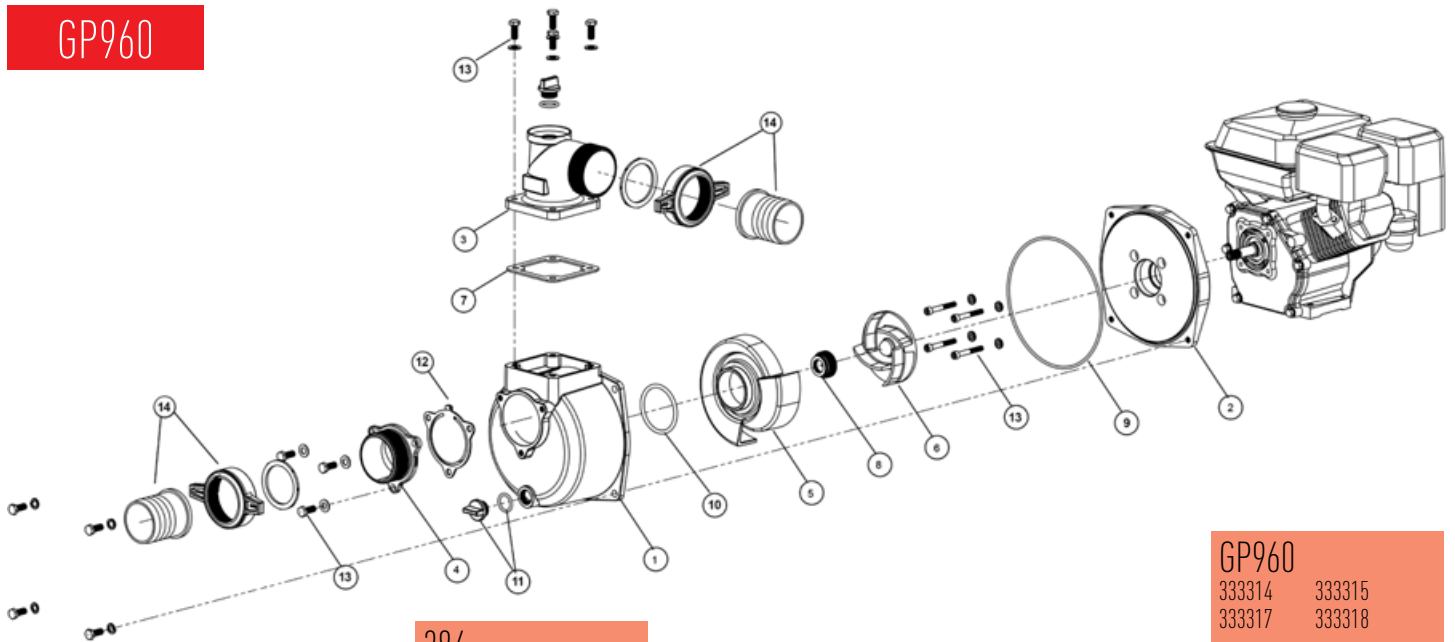

384
 338410 338411
 338425 338426
 338427 338428
 338429

GP960
 333314 333315
 333317 333318

REF NO.	COMPONENT DESCRIPTION	PART NO.	
1	CASING & STUD ASSY.	800283	1PC
2	STUD (PK 10)	800113	4PC
3	O'RING DIFFUSER	702192	1PC
4	DIFFUSER	301884	1PC
5	YOKE	302700GN	1PC
8	O'RING CASING	700207K	1PC
9	SEAL	702617	1PC
10	IMPELLER	505854	1PC
11	NUT (PK 12)	800093	4PC
12	PLUG & O'RING	800017K	2PC
13	PLUG DRAIN	700230	1PC

REF NO.	COMPONENT DESCRIPTION	PART NO.	
1	CASING	801000	1PC
2	YOKE - TO SUIT 45MM SEAL	801227	1PC
3	FLANGE - DELIVERY	801002	1PC
4	FLANGE - SUCTION	801003	1PC
5	DIFFUSER	705077	1PC
6	IMPELLER	705078	1PC
7	DISCHARGE GASKET	REF. 15	1PC
	SEAL ASSEMBLY 45MM	705089	1PC
8	SEAL KIT 40MM (INC. SEAL + 9, 10 & 12)	800889K	1PC
	SEAL KIT 45MM (INC. SEAL + 9, 10 & 12)	800917K	1PC
9	ORING - CASING	REF. 15	1PC
10	ORING - DIFFUSER	REF. 15	1PC
11	DRAIN PLUG	705084	1PC
12	CLACKER CHECKVALVE	REF. 15	1PC
13	BOLT KIT (CASING/SUCTION/DISCHARGE)	705088K	1PC
14	NUT & TAIL KIT (INC. HOSE CLIP)	705094K	1PC
15	GASKET KIT (INC. 7, 9, 10 & 12)	705088K	1PC

OJ SERIES

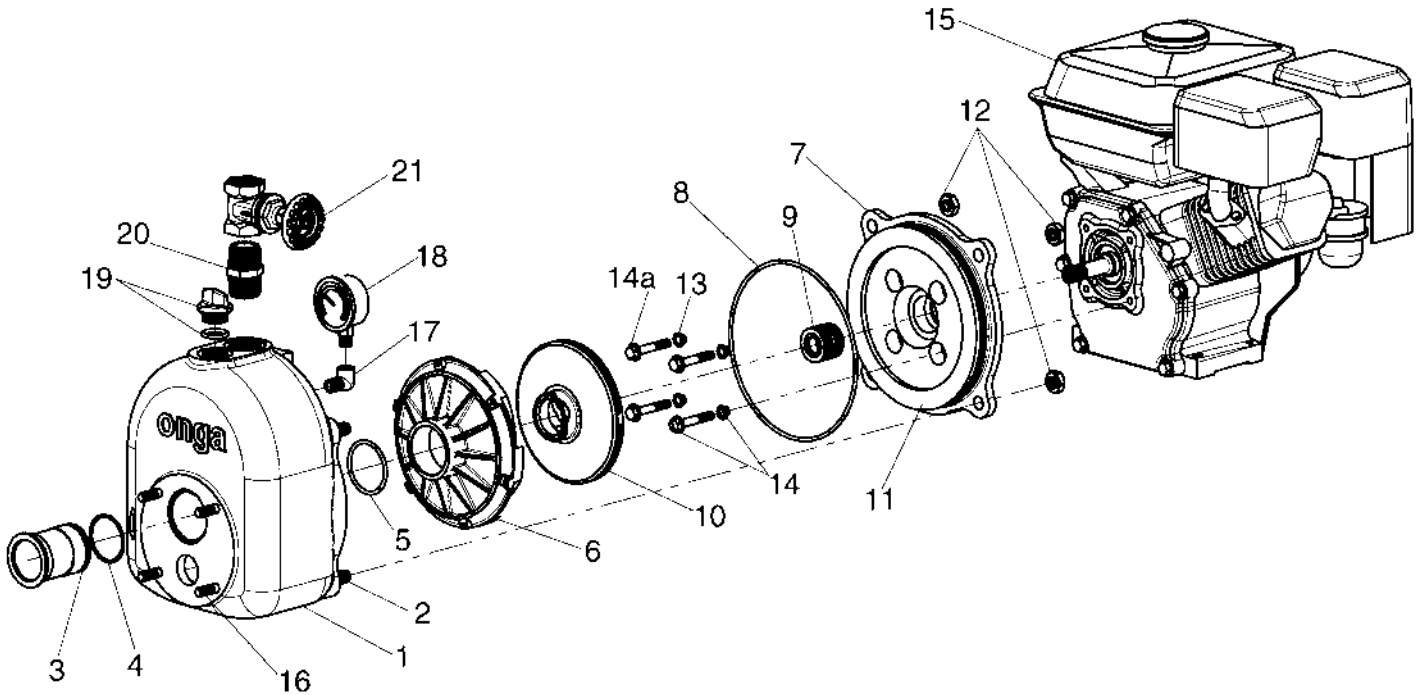

OJ700	OJ800	
1100075	110160	110161

REF NO.	COMPONENT DESCRIPTION	PART NO.		PART NO.	
1	CASING & STUDS ASSY.	800080	1PC	800080	1PC
2	CASING STUD (PK 10)	800113	4PC	800113	4PC
3	SPIGOT	507011	1PC	507011	1PC
4	ORING SPIGOT (PK 5)	702210K	1PC	702210K	1PC
5	O'RING DIFFUSER (PK 5)	700219K	1PC	700219K	1PC
6	DIFFUSER	301431K	1PC	401580K	1PC
7	YOKE	301270GN	1PC	301270GN	1PC
8	O'RING CASING	702165K	1PC	702165K	1PC
9	SEAL	700270K	1PC	702617	1PC
	SEAL (PK 25)	800890K	1PC	NA	1PC
10	IMPELLER	503690	1PC	505484	1PC
11	BAFFLE	401322	1PC	401323	1PC
12	NUT (PK 12)	800093K	4PC	800093K	4PC
	BOLT SEAL (PK 12)	800107K	4PC	800107K	4PC
13	BOLT & SEAL - B&S / HONDA (PK 12)	800273K	4PC	NA	
	BOLT - DIESEL 4.8HP (PK 12)	800398K	4PC	NA	
14	BOLT - DIESEL 6.0HP (PK 12)	NA		800541	1PC
16	STUDS (PK 12)	800114	4PC	800114	4PC
17	ELBOW	700032	1PC	700032	1PC
18	PRESSURE GAUGE	700240K	1PC	700240K	1PC
19	PRIMING PLUG & ORING	800017K	1PC	800017K	1PC
20	NIPPLE	502291	1PC	502291	1PC
21	GATE VALVE	500490	1PC	500490	1PC
23	SCREWS (PK 10)	800399	4PC	800399	4PC
25	NUT (PK 12)	800163K	4PC	800163K	4PC

Drawings are indicative only, product appearance may change slightly.

ACCESSORIES

BLAZEMASTER

ENGINE DRIVEN FIRE FIGHTING SYSTEMS

VITON SEAL KITS

These kits include all elastomeric components, and some internal components:

- Drain Plug o-ring.
- Suction gasket (including clacker).
- Suction/Diffuser o-ring.
- Stainless steel stub shaft.
- Discharge gasket.
- Casing o-ring.
- Second stage diffuser o-ring.
- Stainless/Viton/Carbon/Ceramic mechanical seal.

PART NO.	DESCRIPTION	MODEL COMPATIBILITY
801365K	Seal Kit Blazemaster Single/Twin Viton 1"	•BM90H •BM90HE •BM13HE •BM70Y •BM70YE •BM10YE
801364K	Seal Kit Blazemaster Single/Twin Viton 3/4"	•BM55H •BM65H •BM65HE •B50H •B55H •B65H •B65HE

ROLL FRAMES

These Roll Frames come powdercoated, with rubber feet assembled to the frame. They are delivered with all fasteners required to mount pump to frame. Aside from mounting the pump in the frame, no assembly is required.

PART NO.	DESCRIPTION	MODEL COMPATIBILITY
801372K	Roll Frame Blazemaster Small	Single Stage: GP960, B50H, B55H, B65H, B65HE Twin Impeller: BM55H, BM65H, BM65HE
801373K	Roll Frame Blazemaster Large	Single Stage: B90H, B90HE, B48Y, B70Y, B70YE, B10YE Twin Impeller: BM90H, BM90HE, BM70Y, BM70YE, BM10YE



HOSE KITS

PART NO.	DESCRIPTION	
	SUCTION	STANDARD IN KITS
701124	• 1 x 6m grey suction hose 38mm ID	• 2 x 10m yellow delivery hose 20mm ID • 2 x adjustable fire nozzles
701126	• 1 x 6m grey suction hose 50mm ID	• Nut & Tails • Suction Strainer • Stainless steel hose clamps



*There are no gate valves supplied with the kits. Can be purchased separately.

OPTIONS FOR DIESEL ENGINES

BLAZEMASTER

ENGINE DRIVEN FIRE FIGHTING SYSTEMS

ACP200 - Auto Start/Stop system.

This system is designed to be flexible enough to operate with most applications. It can be used as a "demand start" for generators, be controlled by an "irrigation" controller, programmed for 3 different 7 day programs or simply stopped or started by float or pressure switches.

It Shuts down on low oil, high water temperature, low radiator level (TNV & JCB only) and fan belt failure.

FEATURES:

- Sturdy weatherproof cabinet.
- Various input/output stop methods.
- Inbuilt engine protection.
- Locally designed and built.
- Full engine protection.
- 7 day/24hour programmable timer.
- Manual override.
- Digital hour meter.
- Pump loss of prime switch.
- Supplied Fully wired on new engines or gensets.
- External emergency 'E' stop button.



OPTIONS FOR L-SERIES AIR COOLED ENGINES

ACD-EC90

- Low oil pressure • "E" Stop Button
- Low battery volts • First out indicator • Weather proof cabinet

ACD-EC150

- Low oil pressure • Tachometer • "E" Stop Button • Hour meter
- First out indicators • Low battery volts • Count down timer
- Weather proof cabinet • 1 x Spare Input (eg float level)

ACD-EC90



ACD-E150





1-21 Monash Drive,
Dandenong South, Vic 3175

Australia

National Customer Service: Phone: 1300 137 344
Fax: 1800 006 688
National Dealer Locator: Phone: 1800 664 266
Email: au.sales@pentair.com
Web: www.pentair.com.au

New Zealand

National Customer Service: Phone: 0800 654 112
Fax: 0800 806 642
National Dealer Locator: Phone: 0800 664 269
Email: nz.sales@pentair.com
Web: www.pentair.co.nz

International Australia/New Zealand

Phone: +61 3 9709 5800
Fax: +61 3 9709 5888

© Information contained here-in remains the property of Pentair Pty Ltd. Any reproduction, display, publication, modification or distribution is strictly prohibited without the prior written permission of Pentair Pty Ltd.

Disclaimer: Pentair reserves the right to change product specifications and products details. All product images are for reference purposes only and may not represent actual and/or current product.

L100162 0915